

# TWR-WIFI-GS1500M

---

## User's Manual

Rev. 1.0

## Contents

<b>1 Overview .....</b>	<b>3</b>
<b>2 Reference Documents.....</b>	<b>4</b>
<b>3 Hardware Features.....</b>	<b>4</b>
3.1 GainSpan GS1500M Module.....	4
3.2 System Power.....	4
3.3 Special I/O, access headers, etc.....	5
3.4 LED, Switches and Buttons .....	5
3.5 Elevator Connections .....	5
<b>4 Jumper Table .....</b>	<b>8</b>

## Revision History

Revision	Date	Changes
1.0	Sept 2012	Initial Release

# 1 Overview

The GainSpan Wi-Fi Tower Module (TWR-WIFI-GS1500M) is a low-cost evaluation, demonstration and development board that features an 802.11b/g/n (GS1500M) solution from GainSpan. The following list summarizes the features of the modules:

- GainSpan Wi-Fi module
  - GS1500M is compliant to 802.11b/g/n and operates with standard 802.11 b/g/n access points at speeds up to 72 Mbps
    - Supports standby, deep-sleep, and 802.11 PS-POLL for low power states
    - Supports Infrastructure, Adhoc, Limited AP and Wi-Fi Direct modes
  - UART and SPI interfaces
    - Clock rates up to 1.4 MHz in SPI Slave Mode
    - Up to 921.6 kbps baud rate on UART
  - Full Wi-Fi stack including WPS and optional networking stack and services
  - 802.11i Security
    - WEP, WPA, WPA2-PSK, Enterprise
  - Embedded Web Server for Provisioning
  - Certified RF Module: FCC/IC, ETSI, RoHS, Compliant with JAPAN regulatory

A block diagram for the GainSpan module Based Tower is shown in the figure below.

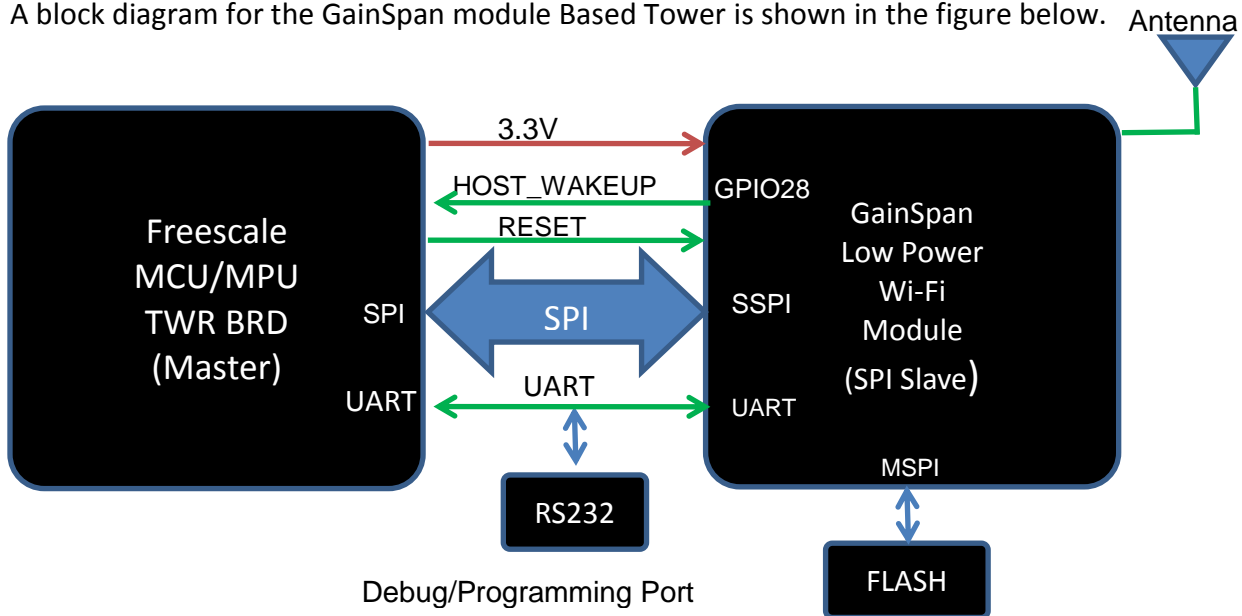

Figure 1. TWR-WIFI-GS1500M Block Diagram

## 2 Reference Documents

---

The documents listed below should be referenced for more information on the Freescale Tower system and the TWR-WIFI-G1500M. Refer to <http://www.freescale.com/tower> for the latest revision of all Tower documentation.

- *TWR-WIFI- GS1500M Quick Start Guide*
- *TWR-WIFI- GS1500M Lab Tutorial*
- *TWR-WIFI- GS1500MSchematics*
- *GainSpan Serial to Wi-Fi Adapters Guide*

For technical documents on the GainSpan Wi-Fi module refer to <http://www.gainspan.com>

## 3 Hardware Features

---

This section provides more details about the features and functionality of the TWR-WIFI Module.

### 3.1 GainSpan GS1500M Module

GainSpan module is a highly integrated ultra low power Wi-Fi module that contains the following:

- Contains media access controller (MAC), baseband processor, on-chip flash memory and SRAM, and a network processor in a single package.
- Built in certified PCB trace antenna or external Antenna and on board regulators, 32 KHz & 44 MHz crystal circuitries.
  - The GS1500M has capability of up to 14dBm (typical) output power at the antenna
- Module includes a variety of I/O interfaces:
  - Two UART with optional hardware flow control support
  - Two SPI block with Master or Slave Operation
  - I<sup>2</sup>C with Master or slave operation
  - Two low-power 10-bit ADC capable of running at up to 32 Ksamples/Sec.,
  - GPIO's, and LED Drivers/GPIO with 20mA capabilities, JTAG

The Module carries on-board single supply monitor for under voltage supply and on-board 1.8V regulator with enable/disable capabilities for power critical applications. For additional details refer to the GS1500M data sheet available from GainSpan. The module connects to the Freescale Tower platform using either UART or the SPI interface. The module firmware supports basic AT command set and has the network stack built in so the driver is bare metal driver for the K60 MCU.

### 3.2 System Power

The module is powered by 3.3V from the Primary Elevator connector.

### 3.3 Special I/O, access headers, etc.

The firmware on the GainSpan module runs directly from the on-board flash on the module. To allow for updating of the program on the flash, the tower module incorporates a UART serial interface for programming purposes. This interface is brought out to a standard RS232 DB9 connector via a RS232 transceiver. In addition to the serial interface, a switch is also provided on the board to put the module in programming mode.

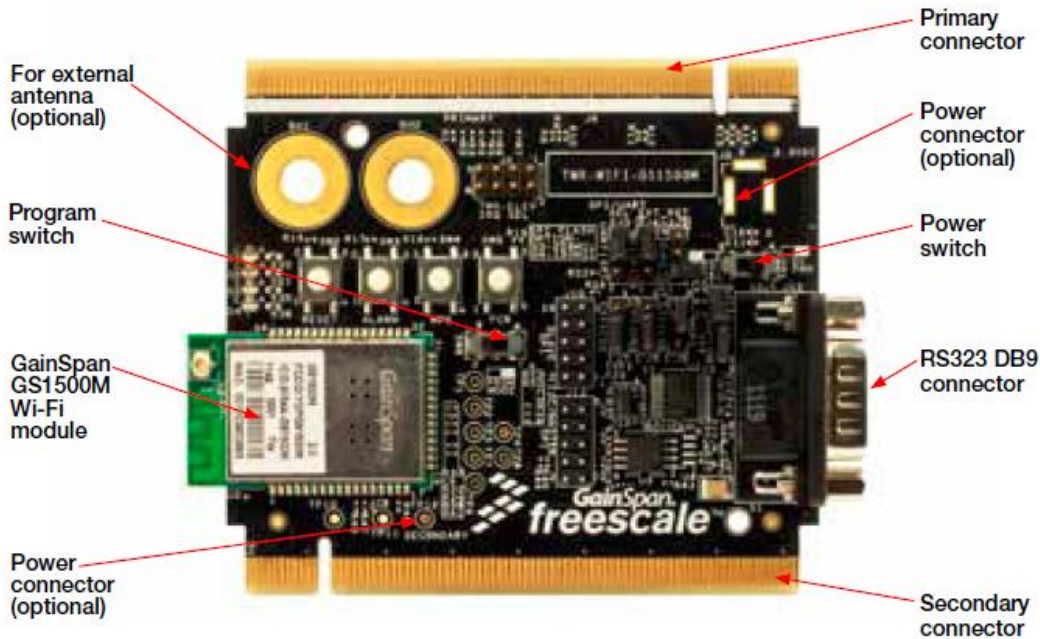

### 3.4 LED, Switches and Buttons

The tower modules contain various LEDs, switches and Buttons that perform different functions or provide status information. The table below provides a brief description of the each of them.

Table 1. TWR-WIFI-GS1500M Switch/LED/Button Table

Item	Type	Label	Description
SW2	Button	Reset	Resets the module
SW3	Button	Alarm	Alarm input to wake module up from deepsleep or standby power save state
SW4	Button	WPS	Not used
SW5	Button	Factory Restore	Not used
D1, D4	LED	LED	Power Indication
D2, D3	LED	LED	SW controlled using AT command from Module

### 3.5 Elevator Connections

The tower module features two expansion card-edge connectors that interface to Elevator boards in a Tower system: the Primary and Secondary Elevator connectors. The Primary Elevator connector, comprised of sides A and B, is utilized by the tower module, while the Secondary Elevator connector

only makes connections to ground (GND). Table 2 provides the pinout for the Primary Elevator Connector. An “X” in the “Used” column indicates that there is a connection from the TWR-WIFI-GS1500M to that pin on the Elevator connector. An “X” in the “Jmp” column indicates that a jumper is available that can configure or isolate the connection from the Elevator connector.

Table 2. TWR-WIFI-GS1500M Primary Elevator Connector Pin-out

TWR-WIFI-G1011MI/GS1500M Primary Connector									
Side B					Side A				
Pin #	Name	Usage	Used	Jmp	Pin #	Name	Usage	Used	Jmp
B1	5V				A1	5V			
B2	GND	Ground	X		A2	GND	Ground	X	
B3	3.3V	3.3V Power	X		A3	3.3V	3.3V Power	X	
B4	ELE_PS_SENSE				A4	3.3V	3.3V Power	X	
B5	GND	Ground	X		A5	GND	Ground	X	
B6	GND	Ground	X		A6	GND	Ground	X	
B7	SPI1_CLK / SDHC1_CLK	MSPI_CLK			A7	SCL0			
B8	SPI1_CS1 / SDHC1_CS1	MSPI_CSx			A8	SDA0			
B9	SPI1_CS0 / SDHC1_CS0	MSPI_CSx			A9	GPIO9 / CTS1	EXT_RESET	X	X
B10	SPI1_MOSI / SDHC1_CMD	MSPI_DIN			A10	GPIO8 / SDHC_D2			
B11	SPI1_MISO / SDHC1_D0	MSPI_DOUT			A11	GPIO7 / SD_WP_DET			
Mechanical Key									
B12	ETH_COL				A12	ETH_CRS			
B13	ETH_RXER				A13	ETH_MDC			
B14	ETH_TXCLK				A14	ETH_MDIO			
B15	ETH_TXEN				A15	ETH_RXCLK			
B16	ETH_TXER				A16	ETH_RXDV			
B17	ETH_TXD3				A17	ETH_RXD3			
B18	ETH_TXD2				A18	ETH_RXD2			
B19	ETH_TXD1				A19	ETH_RXD1			
B20	ETH_TXD0				A20	ETH_RXD0			
ipB21	GPIO1	GPIO_RST	X	X	A21	SSI_MCLK			
B22	GPIO2	GPIO29			A22	SSI_BCLK			
B23	GPIO3	GPIO19			A23	SSI_FS			
B24	CLKIN0				A24	SSI_RXD			
B25	CLKOUT1				A25	SSI_TXD			
B26	GND	Ground	X		A26	GND	Ground	X	
B27	AN7				A27	AN3			
B28	AN6				A28	AN2			
B29	AN5				A29	AN1			
B30	AN4				A30	AN0			
B31	GND	Ground	X		A31	GND	Ground	X	
B32	DAC1				A32	DAC0			
B33	TMR3				A33	TMR1			
B34	TMR2				A34	TMR0			
B35	GPIO4	DC_DC_CNTL			A35	GPIO6	ALARM2		
B36	3.3V	3.3V Power	X		A36	3.3V	3.3V Power	X	
B37	PWM7				A37	PWM3			

B38	PWM6				A38	PWM2			
B39	PWM5				A39	PWM1			
B40	PWM4				A40	PWM0			
B41	CANRX				A41	RXD0	UART0_TX	X	
B42	CANTX				A42	TXD0	TWR_UART0	X	X
B43	1WIRE				A43	RXD1			
B44	SPI0_MISO	SSPI_DOUT	X		A44	TXD1			
B45	SPI0_MOSI	SSPI_DIN	X		A45	GPIO			
B46	SPI0_CS0	SSPI_CS	X	X	A46	GPIO			
B47	SPI0_CS1	SSPI_CS	X	X	A47	GPIO			
B48	SPI0_CLK	SSPI_CLK	X		A48	GPIO			
B49	<b>GND</b>	<b>Ground</b>	<b>X</b>		A49	<b>GND</b>	<b>Ground</b>	<b>X</b>	
B50	SCL1	I2C_CLK			A50	GPIO			
B51	SDA1	I2C_DATA			A51	GPIO			
B52	GPIO5	ALARM1	X		A52	GPIO			
B53	USB_DP_PDOWN				A53	GPIO			
B54	USB_DM_PDOWN				A54	USB_DM			
B55	IRQ_H				A55	USB_DP			
B56	IRQ_G	GPIO28	X	X	A56	USB_ID			
B57	IRQ_F				A57	USB_VBUS			
B58	IRQ_E	GPIO28	X	X	A58	TMR7			
B59	IRQ_D				A59	TMR6			
B60	IRQ_C	GPIO28	X	X	A60	TMR5			
B61	IRQ_B				A61	TMR4			
B62	IRQ_A	GPIO28	X	X	A62	RSTIN_b			
B63	FB_ALE/FB_CS1_b				A63	RSTOUT_b	EXT_RESET	X	X
B64	FB_CS0_b				A64	CLKOUT0			
B65	<b>GND</b>	<b>Ground</b>	<b>X</b>		A65	<b>GND</b>	<b>Ground</b>	<b>X</b>	
B66	FB_AD15				A66	FB_AD14			
B67	FB_AD16				A67	FB_AD13			
B68	FB_AD17				A68	FB_AD12			
B69	FB_AD18				A69	FB_AD11			
B70	FB_AD19				A70	FB_AD10			
B71	FB_R/W_b				A71	FB_AD9			
B72	FB_OE_b				A72	FB_AD8			
B73	FB_D7				A73	FB_AD7			
B74	FB_D6				A74	FB_AD6			
B75	FB_D5				A75	FB_AD5			
B76	FB_D4				A76	FB_AD4			
B77	FB_D3				A77	FB_AD3			
B78	FB_D2				A78	FB_AD2			
B79	FB_D1				A79	FB_AD1			
B80	FB_D0				A80	FB_AD0			
B81	<b>GND</b>	<b>Ground</b>	<b>X</b>		A81	<b>GND</b>	<b>Ground</b>	<b>X</b>	
B82	<b>3.3V</b>	<b>3.3V Power</b>	<b>X</b>		A82	<b>3.3V</b>	<b>3.3V Power</b>	<b>X</b>	

## 4 Jumper Table

There are several jumpers provided for isolation, configuration, and feature selection. Refer to the following table for details. The default installed jumper settings are highlighted below.

Table 3. TWR-WIFI-GS1500M Jumper Table

Jumper	Option	Setting	Description
SW1	Power Supply Input	<b>ELEV PWR</b>	Power from Tower System 3.3V
		DC PWR	Power from DC power jack (J2)
SW6	Mode Selection	<b>RUN</b>	GS1500M in standard "run" mode
		PRGM	GS1500M in program mode
J1	Interrupt Selection	1-2	Connect GS1500M interrupt to Tower IRQ_G (B56)
		3-4	Connect GS1500M interrupt to Tower IRQ_E (B58)
		5-6	Connect GS1500M interrupt to Tower IRQ_C (B60)
		<b>7-8</b>	Connect GS1500M interrupt to Tower IRQ_A (B62)
J3	SPI/UART Selection <sup>1</sup>	<b>1-2</b>	Select SPI as serial interface
		2-3	Select UART as serial interface
J4	GS1500M Reset Selection	1-2	Connect GS1500M Reset to Tower GPIO9 (A9)
J5		<b>2-3</b>	No connection
J5		<b>1-2</b>	Connect GS1500M Reset to Tower RSTOUT (A63)
J7	Slave SPI Port CS Selection	2-3	Connect GS1500M Reset to Tower GPIO1 (B21)
		<b>1-2</b>	Connect Tower SPI0_CS0 to slave SPI CS on GS1500M
J8	UART Routing Selection	2-3	Connect Tower SPI0_CS1 to slave SPI CS on GS1500M
		<b>1-2</b>	Connect GS1500M UART0 to on-board RS232/DB9
J9	Master SPI Port CS Selection	2-3	Connect GS1500M UART0 to Tower System
		<b>1-2</b>	Connect Tower SPI1_CS1 to master SPI CS on GS1500M
J11	Power Isolation and Current Measurement	2-3	Connect Tower SPI1_CS0 to master SPI CS on GS1500M
		<b>ON</b>	Connect GS1500M power supplies to the 3.3V supply source
J14	RS232 Transceiver Force-off	OFF	Isolate GS1500M from power supplies. J11 can be used to measure the energy consumption of the VBAT, VDDIO, and EN_1V8 supplies to the GS1500M.
		<b>ON</b>	RS232 transceiver operates in normal mode
J15	UART CTS Isolation	OFF	RS232 transceiver forced off
		<b>ON</b>	Connect UART0_CTS from GS1500M to RS232 transceiver
		OFF	Disconnect UART0_CTS from RS232 transceiver

Note:

1. This jumper is not applicable with Serial to Wi-Fi firmware. It is applicable with IP-to-Wi-Fi firmware.